

K#790173

I.D. 40 mm CUT 17 mm  
O.D. 61.5 mm GAP 2 mm  
TEETH 10 T.P.I. 1.3

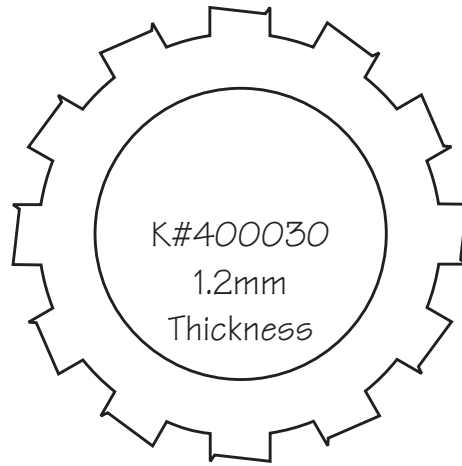

K#400030  
1.2mm  
Thickness

I.D. 40 mm CUT 8 mm  
O.D. 62 mm GAP 8 mm  
TEETH 12 T.P.I. 1.6

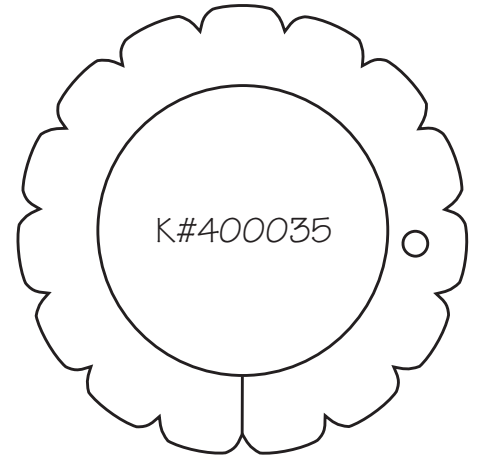

K#400035

I.D. 40 mm CUT 8 mm  
O.D. 62 mm GAP 4 mm  
TEETH 15 T.P.I. 2.0

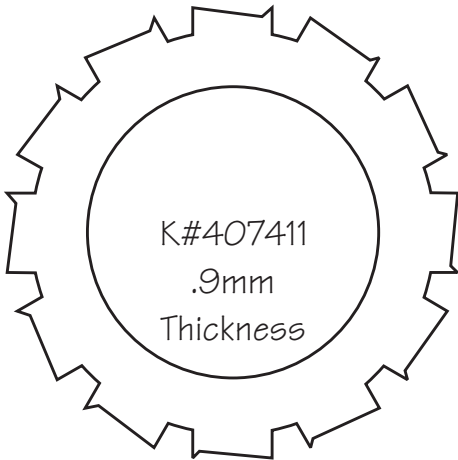

K#407411  
.9mm  
Thickness

I.D. 40 mm CUT 11 mm  
O.D. 64 mm GAP 5 mm  
TEETH 12 T.P.I. 1.6

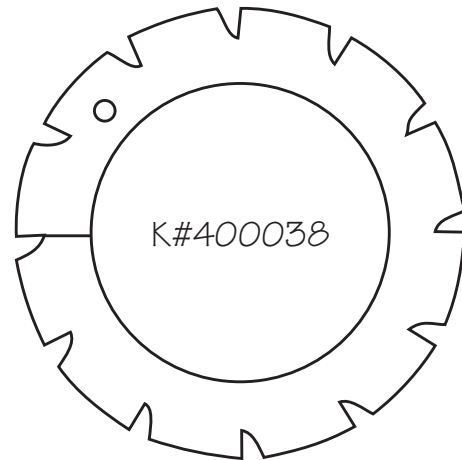

K#400038

I.D. 40 mm CUT 12 mm  
O.D. 62 mm GAP 3 mm  
TEETH 12 T.P.I. 1.6

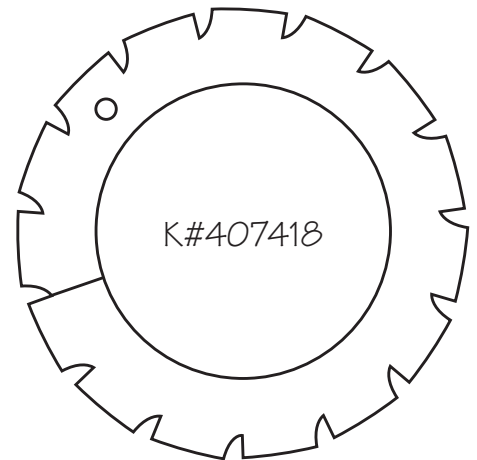

K#407418

I.D. 40 mm CUT 9.5 mm  
O.D. 62 mm GAP 3 mm  
TEETH 15 T.P.I. 2.0

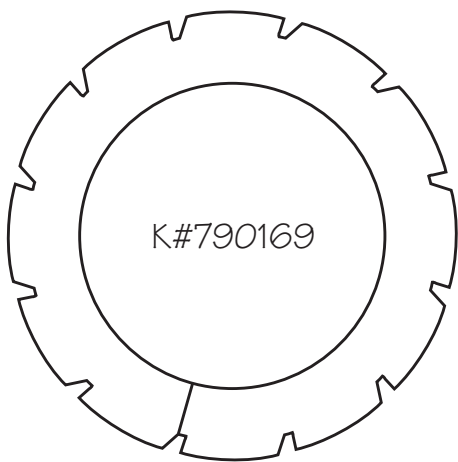

K#790169

I.D. 40 mm CUT 13 mm  
O.D. 61.5 mm GAP 3 mm  
TEETH 12 T.P.I. 1.6

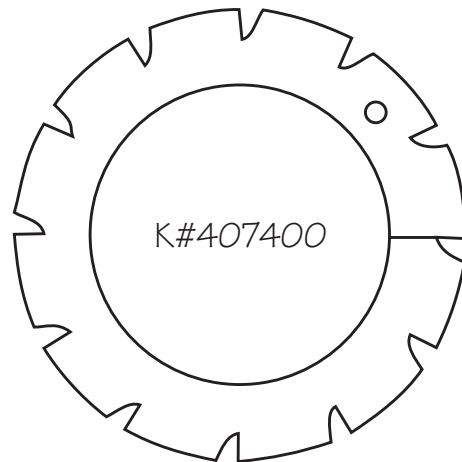

K#407400

I.D. 40 mm CUT 12.5 mm  
O.D. 62 mm GAP 3.5 mm  
TEETH 12 T.P.I. 1.6

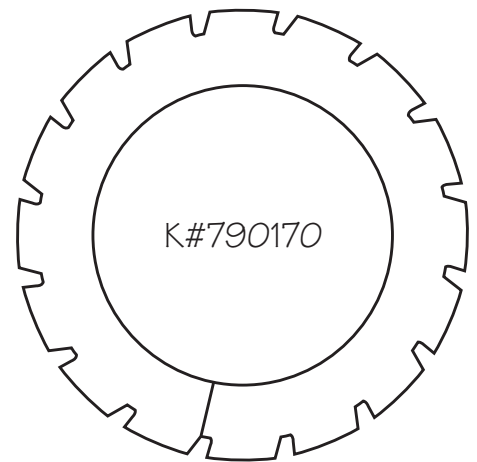

K#790170

I.D. 40 mm CUT 8.5 mm  
O.D. 61.5 mm GAP 3 mm  
TEETH 16 T.P.I. 2.1

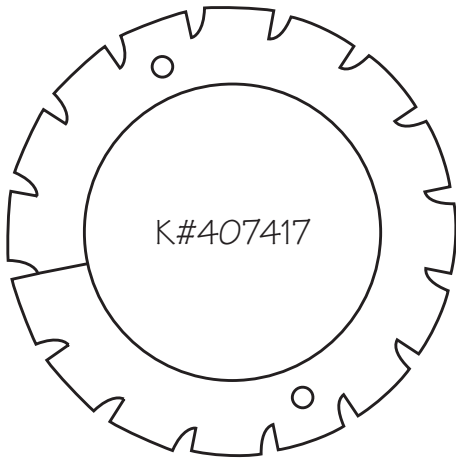

I.D. 40 mm CUT 3.5 mm  
 O.D. 62 mm GAP 5 mm  
 TEETH 16 T.P.I. 2.1

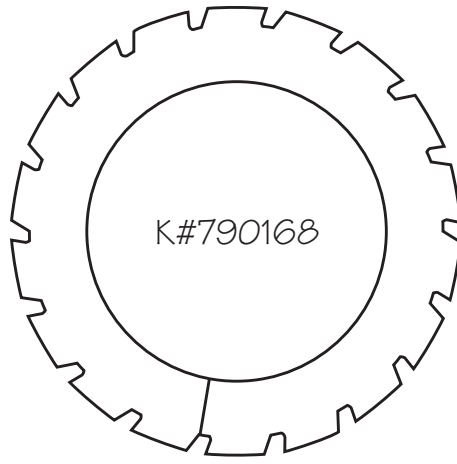

I.D. 40 mm CUT 8 mm  
 O.D. 61.5 mm GAP 2.5 mm  
 TEETH 18 T.P.I. 2.4

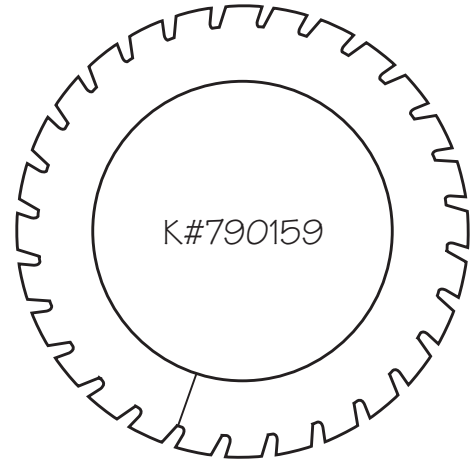

I.D. 40 mm CUT 5 mm  
 O.D. 60 mm GAP 1.5 mm  
 TEETH 28 T.P.I. 3.8

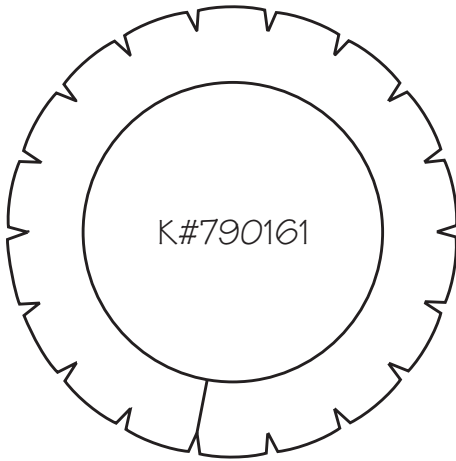

I.D. 40 mm CUT 9 mm  
 O.D. 60 mm GAP 1 mm  
 TEETH 18 T.P.I. 2.4

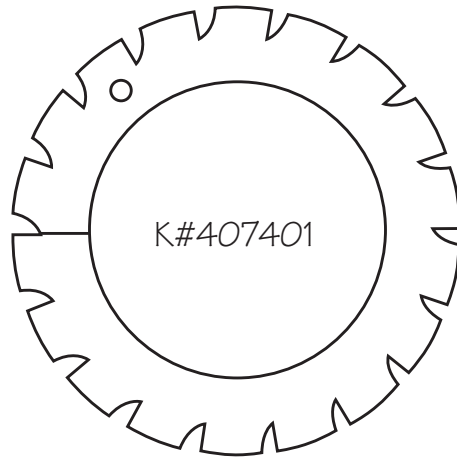

I.D. 40 mm CUT 7.5 mm  
 O.D. 62 mm GAP 3 mm  
 TEETH 18 T.P.I. 2.3

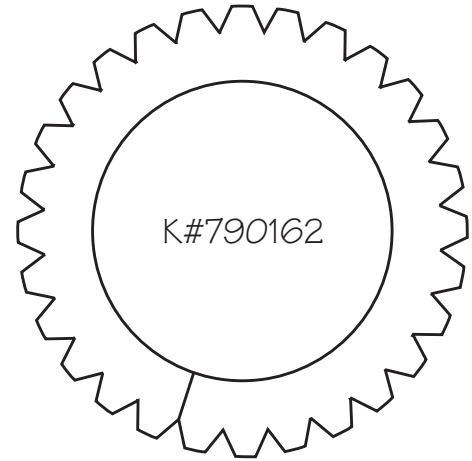

I.D. 40 mm CUT 2.5 mm  
 O.D. 61.5 mm GAP 4 mm  
 TEETH 28 T.P.I. 3.7

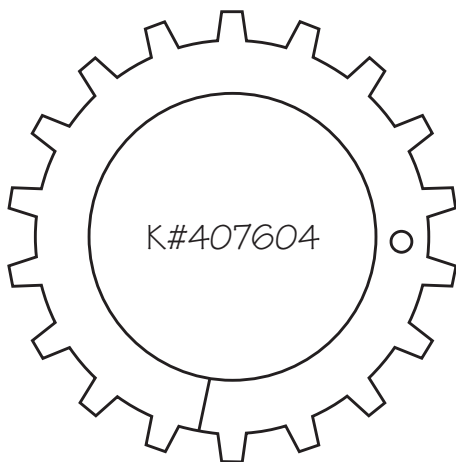

I.D. 40 mm CUT 2.5 mm  
 O.D. 61.5 mm GAP 8 mm  
 TEETH 18 T.P.I. 2.4

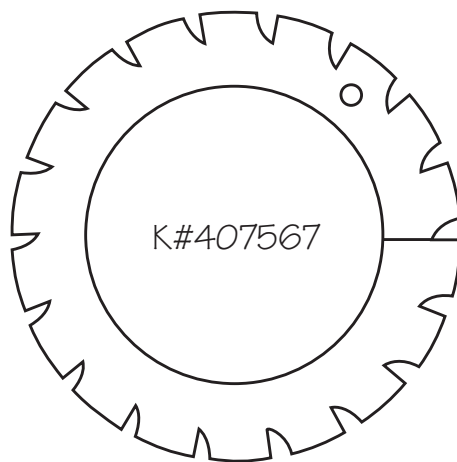

I.D. 40 mm CUT 7.5 mm  
 O.D. 62 mm GAP 3 mm  
 TEETH 18 T.P.I. 2.4

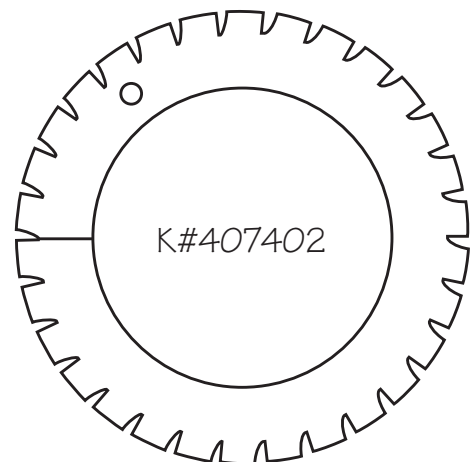

I.D. 40 mm CUT 3 mm  
 O.D. 62 mm GAP 3 mm  
 TEETH 30 T.P.I. 3.9

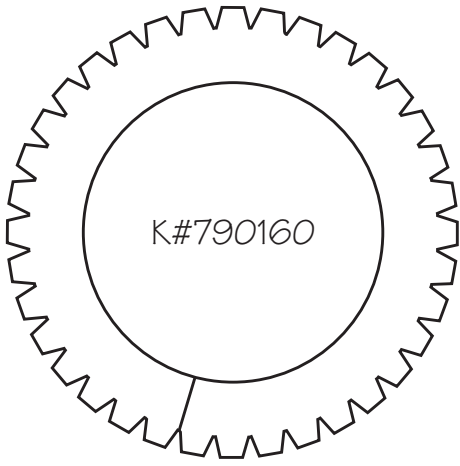

K#790160

I.D. 40 mm CUT 3 mm  
O.D. 60 mm GAP 2 mm  
TEETH 36 T.P.I. 4.9

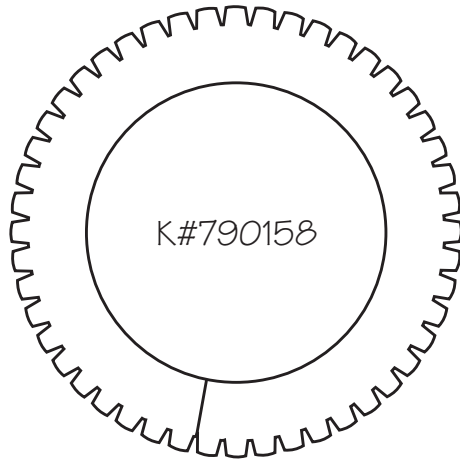

K#790158

I.D. 40 mm CUT 2.5 mm  
O.D. 60 mm GAP 1 mm  
TEETH 48 T.P.I. 6.5

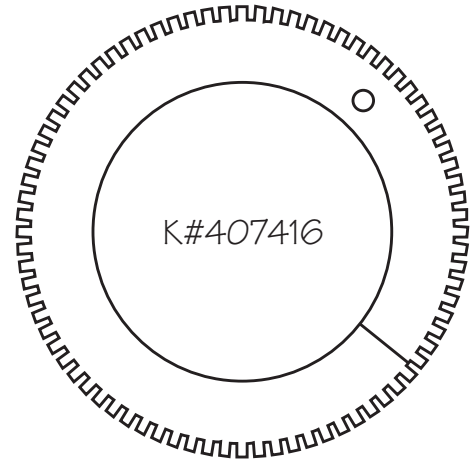

K#407416

I.D. 40 mm CUT 1 mm  
O.D. 60 mm GAP 1 mm  
TEETH 80 T.P.I. 10.8

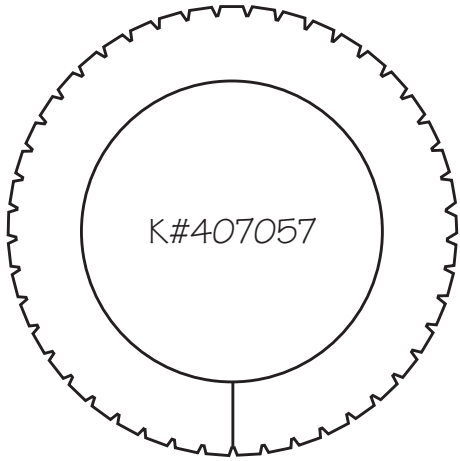

K#407057

I.D. 40 mm CUT 3 mm  
O.D. 61.5 mm GAP 1 mm  
TEETH 45 T.P.I. 5.9

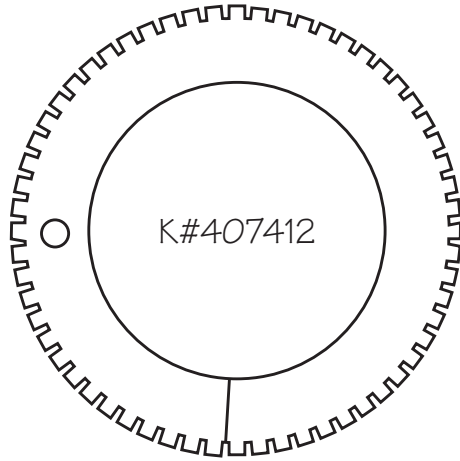

K#407412

I.D. 40 mm CUT 2 mm  
O.D. 60 mm GAP 1 mm  
TEETH 60 T.P.I. 8.1

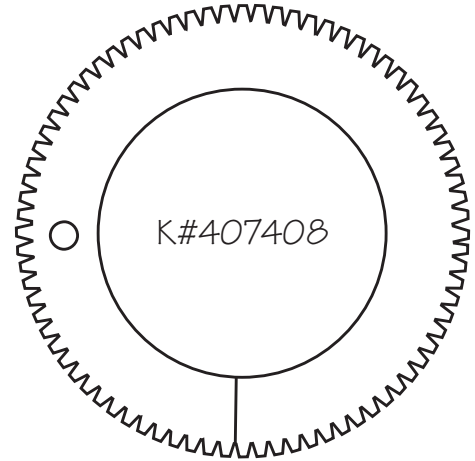

K#407408

I.D. 40 mm CUT 1 mm  
O.D. 61.5 mm GAP 1.2 mm  
TEETH 80 T.P.I. 10.5

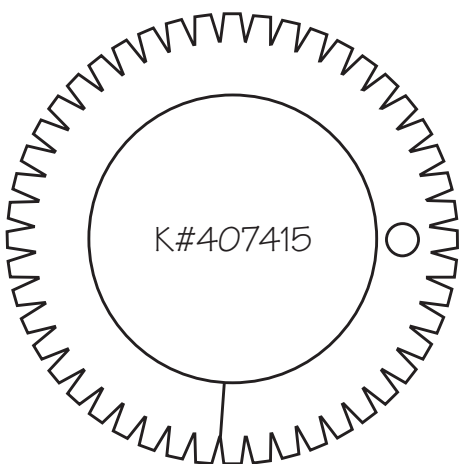

K#407415

I.D. 40 mm CUT 1.5 mm  
O.D. 60 mm GAP 2 mm  
TEETH 48 T.P.I. 6.5

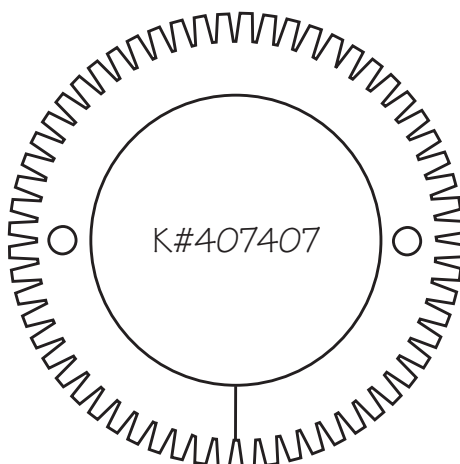

K#407407

I.D. 40 mm CUT 1.5 mm  
O.D. 62 mm GAP 1.5 mm  
TEETH 60 T.P.I. 7.8

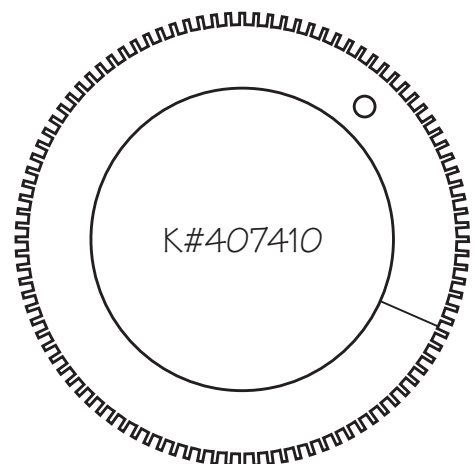

K#407410

I.D. 40 mm CUT 1 mm  
O.D. 61.5 mm GAP 1 mm  
TEETH 100 T.P.I. 14