

**KEPES,
Inc.**

**35mm I.D. PERFS, SCORES,
SLITTERS, and ACCESSORIES**

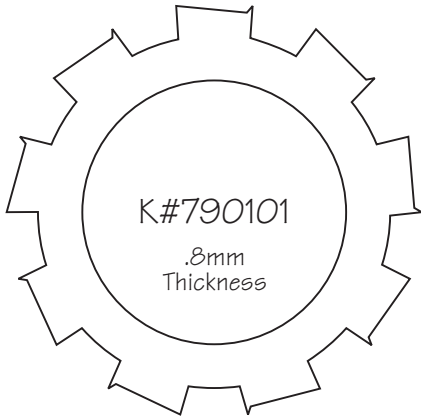

K#790101
.8mm
Thickness

CUT 11 mm GAP 7 mm
TEETH 9 T.P.I. 1.4

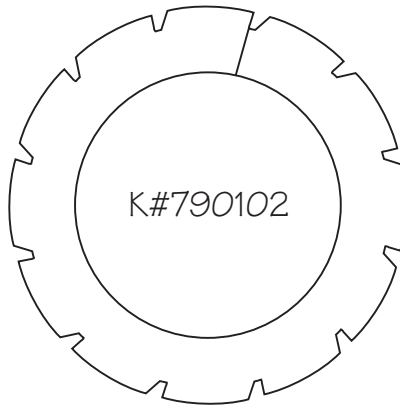

K#790102

CUT 11 mm GAP 2.5 mm
TEETH 12 T.P.I. 1.8

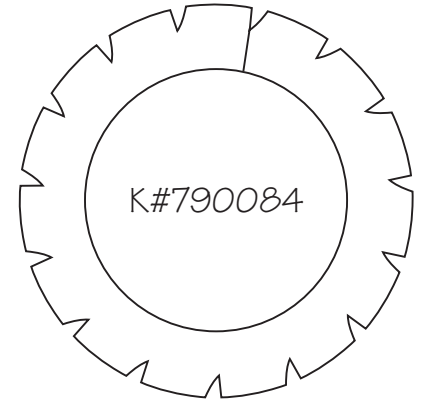

K#790084

CUT 8 mm GAP 3 mm
TEETH 15 T.P.I. 2.3

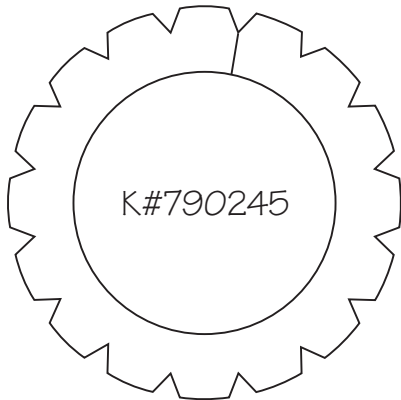

K#790245

CUT 6 mm GAP 4 mm
TEETH 16 T.P.I. 2.4

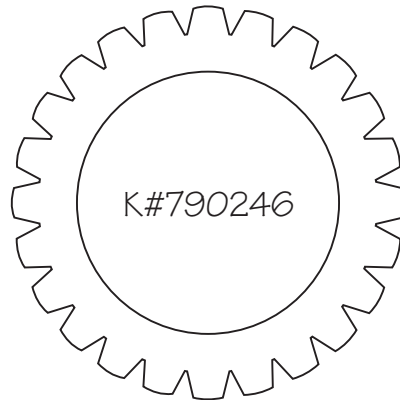

K#790246

CUT 4 mm GAP 4 mm
TEETH 24 T.P.I. 4

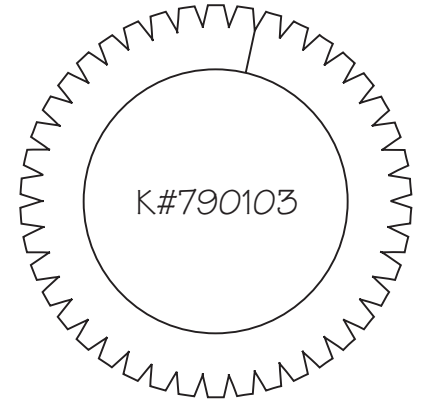

K#790103

CUT 2.5 mm GAP 1 mm
TEETH 42 T.P.I. 6.4

35mm= 1.38 inches
53mm=2.09 inches
54mm= 2.13 inches

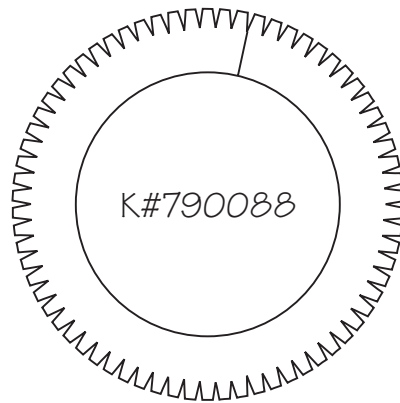

K#790088

CUT 1.5 mm GAP .5 mm
TEETH 70 T.P.I. 10.7

TO CONVERT TO INCHES
MULTIPLY MILLIMETERS x 0.03937

TO CONVERT TO MILLIMETER
MULTIPLY INCHES x 25.4

All perfs, scores, and slitters are .5mm in thickness and 53mm O.D. unless otherwise noted. Perfs are drawn bevel side up.

SCORE, SLITTER AND ACCESSORIES

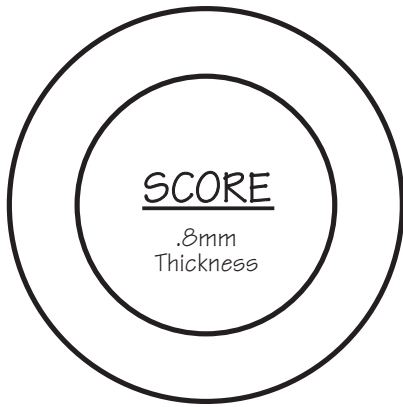

K#790058 O.D. .52 mm
 K#790244 O.D. .51 mm



O.D. .53 mm

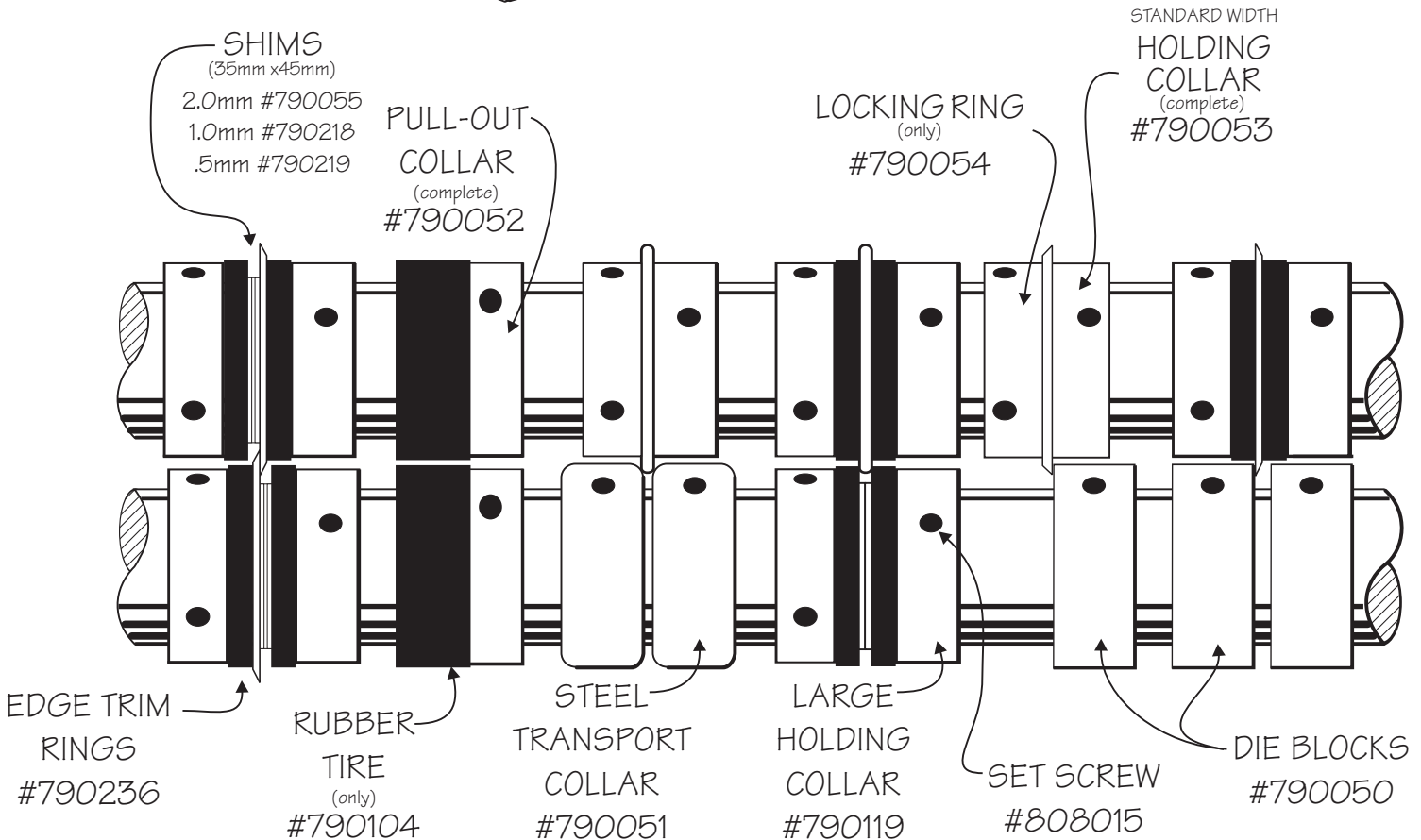
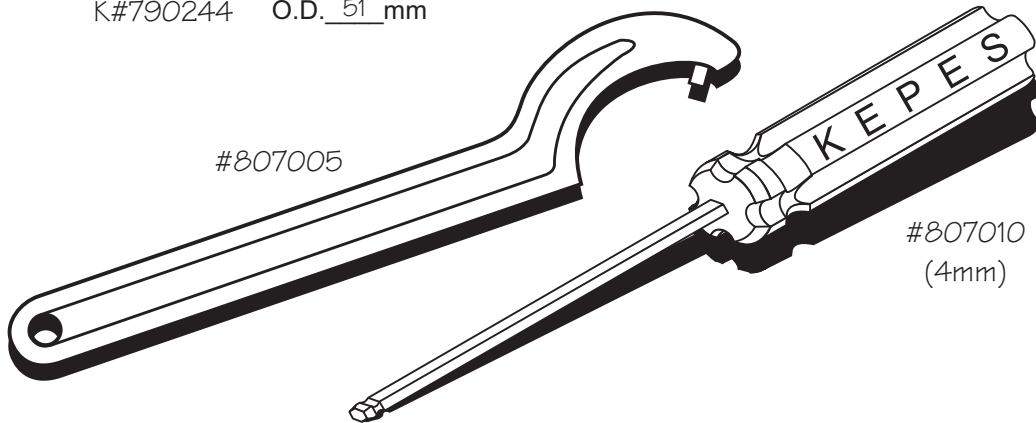

MOST PARTS ARE IN STOCK AND CAN BE SHIPPED THE SAME DAY!!!